

2.5V-12V Output MD1422N

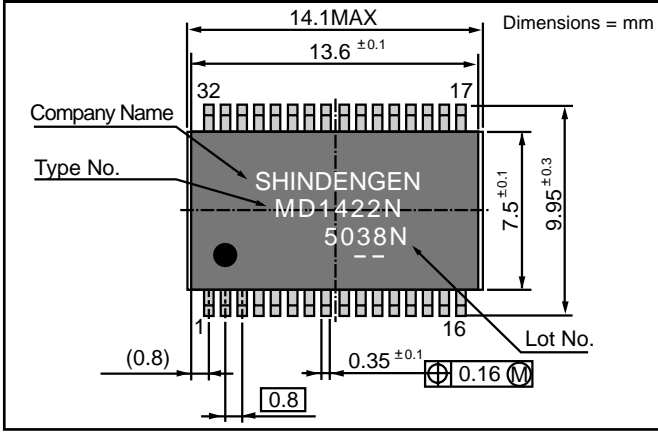

DESCRIPTION

The MD1422N is a high-efficiency step down DC-DC converter power integrated circuit with main MOSFET switch and synchronous rectification MOSFET. The MD1422N can deliver high efficiency over a wide input voltage range. This device has output voltage digitally selectable from 2.5V to 12V. With the MD1422N you can construct a complete DC-DC converter using only a few external components. Featuring an SSOP 32-pin surface mount package, the MD1422N allows you to incorporate a very small and thin power supply on your circuit board.

BLOCK DIAGRAM

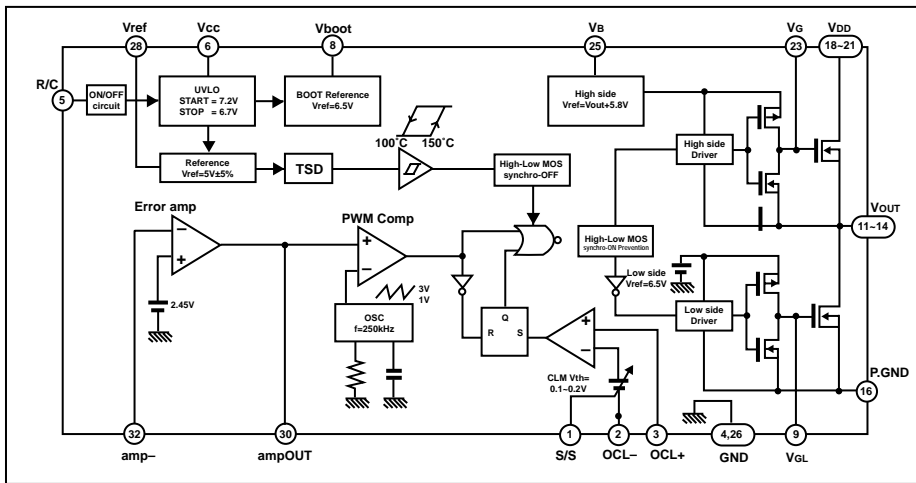

FEATURES

- High efficiency
- Wide input voltage load range
8VDC to 40VDC
Up to 3ADC
- Output voltage selectable function
2.5V to 12V
- Internal Switching power device
Main MOSFET for switch and
synchronous rectification MOSFET
- Fixed 250kHz PWM frequency
(Without external resistor and capacitor)
- Overcurrent protection
- Thermal shutdown function
- Remote control ON/OFF

PIN ASSIGNMENT

Pin#	Symbol	Function description
1	S/S	Capacitor for softstart
2	OCL-	Overcurrent protection (OCL) (-)
3	OCL+	Overcurrent protection (OCL) (+)
4	GND	Signal GND
5	R/C	Remote ON/OFF control terminal
6	Vcc	Input voltage
7	N/C	Non-connection
8	Vboot	High side drive supply for main MOS
9	VGL	Low side MOSFET gate terminal
10	N/C	Non-connection
11 - 14	Vout	Power stage output
15	N/C	Non-connection
16	P.GND	Power GND
17	N/C	Non-connection
18 - 21	V _{DD}	Drain of main MOS Switch
22	N/C	Non-connection
23	V _{GH}	Main switch high side MOSFET gate terminal
24	N/C	Non-connection
25	V _B	Bootstrap capacitor between VB and VOUT
26	GND	Signal GND
27	V _{TS}	Output voltage selectable terminal
28	V _{ref}	Internal voltage reference
29	N/C	Non-connection

30	AmpOUT	Error Amp out
31	N/C	Non-connection
32	amp-	Error Amp (-) input

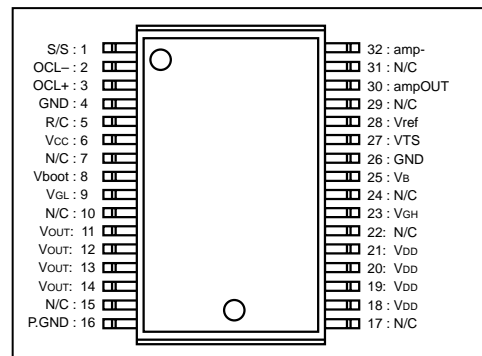

- **V_{ref}** - Temperature compensated internal voltage. You can pull 1mA maximum for external circuit.
- **OSC** - MCD1422N uses internal oscillator without external component. Frequency (Saw tooth wave form) is trimmed to 250kHz on chip.
- **Error Amp** - Error Amp detects output voltage of DC-DC converter and controls PWM signal. You can adjust the loop gain when you connect feedback resistor and capacitor between AmpOUT and Amp (-). It will provide stable phase compensation.
- **Overcurrent protection** - MD1422N uses pulse-by-pulse current protection. Current will be sensed voltage drop of external current sensing resistor. Threshold of OCL is 0.19V.

ABSOLUTE MAXIMUM RATINGS

(Ta=25°C)

Parameter	Symbol	Rating	Units
Input voltage	V _{IN}	42	V
Main MOS voltage	V _{DD}	42	V
Output current (ave)	I _{OUTAVE}	3	A
Output current (peak)	I _{OUTPEAK}	4	A
OCL-, OCL+ terminal voltage	V _{OCL}	5.5	V
Remote control voltage	V _{RC}	5.5	V
Storage temperature	T _{stg}	-40 ~ 150	°C
Junction temperature	T _J	150	°C

RECOMMENDED OPERATION CONDITIONS

Parameter	Recommendation	Units
Input voltage	8 ~ 40	V
Output voltage setting range	2.5-12	V
Operation temperature	-10 ~ 80	°C

OUTPUT CURRENT DERATING FOR 8V OR HIGHER OUTPUT

Output setting voltage	Output current
2.5V ~ 8V	3A
≤ 12V	2.5A

ELECTRIC CHARACTERISTICS

(Ta=25°C)

Parameter	Symbol	Conditions	MIN	TYP	MAX	Units
High side MOS Drain-source breakdown voltage	V _{dss}	I _D =1mA, V _{GS} =0V	42	-	-	V
High side MOS Drain interruption current	I _{dss}	V _{DS} =40V, V _{GS} =0V	-	-	10	μA
High side MOS Drain-source ON resistance	R _{on}	I _D =1.2A, V _{GS} =4.5V	-	33	70	mΩ
High side MOS Source-drain Di forward voltage	V _{SD}	I _S =1.2A, V _{DS} =0V	-	-	1.5	V
Low side MOS Drain-source breakdown voltage	V _{dss}	I _D =1mA, V _{GS} =0V	42	-	-	V
Low side MOS Drain interruption current	I _{dss}	V _{DS} =40V, V _{GS} =0V	-	-	10	μA
Low side MOS Drain-source ON resistance	R _{on}	I _D =1.2A, V _{GS} =4.5V	-	33	70	mΩ
Low side MOS Source-drain Di forward voltage	V _{SD}	I _S =1.2A, V _{DS} =0V	-	-	1.5	V
Start voltage	V _{cc_start}	-	6.5	7.2	7.9	V
Stop voltage	V _{cc_stop}	-	6.0	6.7	7.4	V
Stop-start voltage hysteresis	V _{cc_hys}	-	-	0.5	-	V
Current consumption	I _{cc}	V _{cc} =8V ~ 40V	-	10	13	mA
Current consumption with remote control OFF	I _{cc_off}	V _{cc} =8V ~ 40V	-	1.2	1.5	mA
Remote control terminal ON voltage	V _{RC_ON}	V _{cc} =8V ~ 40V	-0.2	-	0.5	V
Remote control terminal OFF voltage	V _{RC_OFF}	V _{cc} =8V ~ 40V	2.5	-	5.3	V
Remote control terminal shorted voltage	I _{RC}	V _{cc} =8V ~ 40V	-	-	250	μA
BOOT terminal voltage	V _{boot}	V _{cc} =24V	5.4	6.5	7.6	V
Internal reference voltage	V _{ref}	V _{cc} =8V ~ 40V	4.75	5	5.25	V
Internal oscillation frequency	f _{osc}	V _{cc} =24V	212.5	250	287.5	kHz
Overcurrent threshold voltage	V _{th_OCL}	V _{cc} =24V	0.162	0.19	0.218	V
Softstart terminal current	I _{S/S}	V _{cc} =24V	-20	-12.5	-5	μA
Error amplifier reference voltage	V _{amp}	V _{cc} =8V ~ 40V	2.4	2.45	2.5	V
Overcurrent protection operating temperature	T _{TSD}	-	-	150	-	°C